

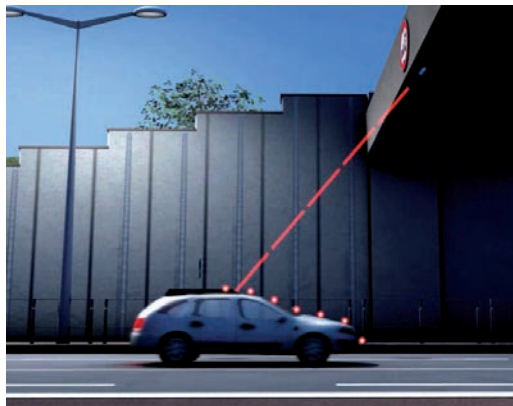

Laser Distance Sensor LDS30

Fast & compact rangefinder for system integration



Description and Features

The LDS30 laser distance sensor is dedicated for general ranging applications that require instantly triggered and fast data acquisition. The sensor provides measurement rates as fast as 30 kHz within a total measurement range of up to 250 m with an absolute measurement accuracy in the centimeter range. It operates fully eyesafe at a wavelength of 905 nm.

The LDS30 sensor is optimized for easy system integration. It is fitted into a ready-to-use IP67 proof housing. The LDS30 is shockproof and suitable for applications that impose high impact on the sensor, for example in industrial environments.

Benefits

- Compact, lightweight design
- High repetition rate
- Long measuring range
- Eyesafe operation
- IP67 proof housing
- Industrial standard interfaces
- Digital and analog output
- Easy system integration

Applications

- Distance measurement & object detection
- Proximity sensing & warning
- 2D and 3D scanning applications
- Industrial automation

Laser Distance Sensor LDS30

Fast & compact rangefinder for system integration

Specifications

Type	LDS30
Total measuring range	0.2 m ... 250 m
Typical measuring range for special targets (e.g. Scotchlite Cube 3000x) for target reflectivity 10% ¹	10 m ... 250 m 0.2 m ... 30 m
Measuring accuracy (for single measurement, 1 σ)	
Absolute accuracy	± 5 cm
Reproducibility	± 2 cm
Measured value resolution	1 mm
Maximum measuring frequency	
binary data output	30 kHz
decimal or binary data output	15 kHz
Laser classification	Laser Class 1, EN 60825-1:2007
Wavelength	905 nm
Laser divergence	3 mrad × 1 mrad
Serial data interface	RS232, RS422
Switching output	2x „high side“, up to 0.2 A
Analog output	4 mA ... 20 mA
Power supply	10 VDC ... 30 VDC
Power consumption (max.)	3 W
Operating temperature	0 °C ... +50 °C
Humidity	10% ... 90%, not condensing
Internal protection class	IP 67
Shock / vibration	DIN ISO 9022-3
EMC	EN 61326-1
Dimensions	86 mm × 45 mm × 45 mm (L×W×H, incl. connector)
Weight	approx. 125 g

¹ Measuring range for natural, diffuse reflecting surfaces, depending on target reflectivity, stray light and environmental conditions.

Dimensions LDS30

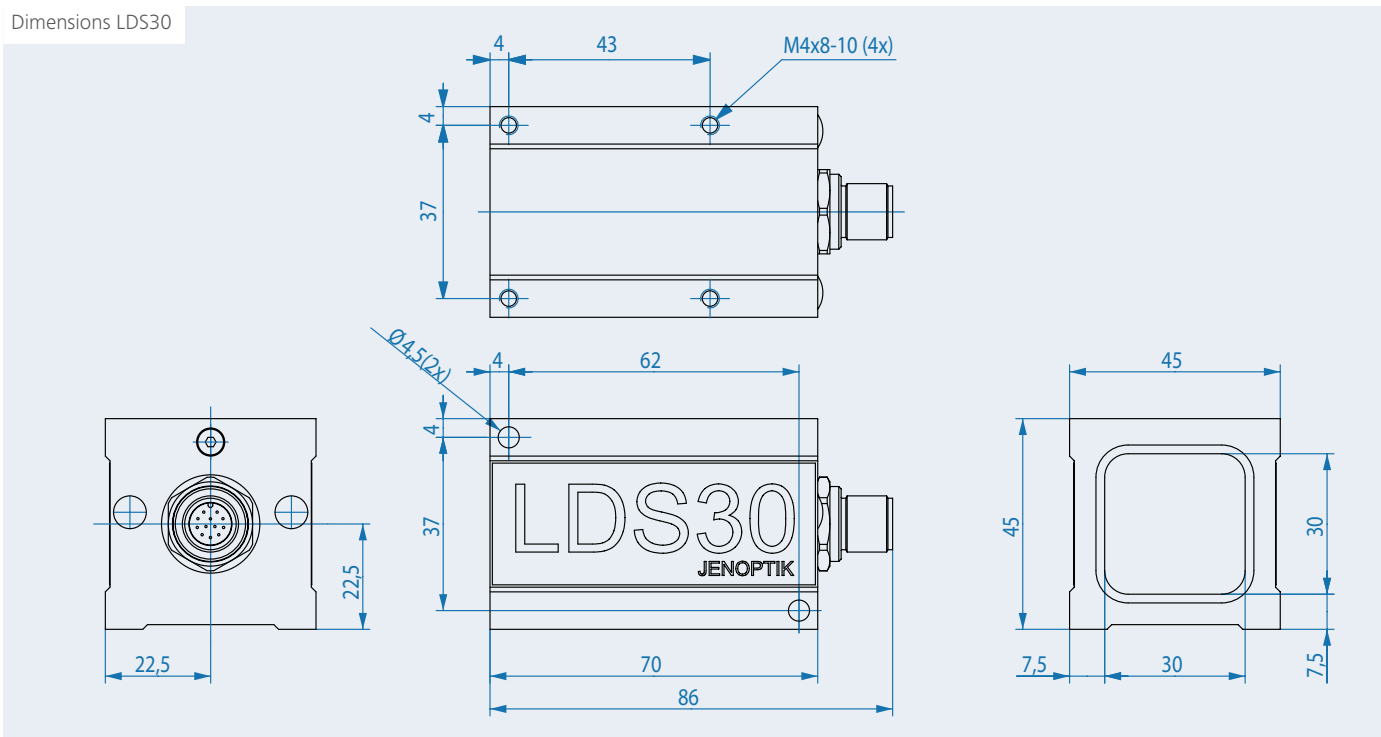

It is our policy to constantly improve the design and specifications. Accordingly, the details represented herein cannot be regarded as final and binding.



JENOPTIK | Defense & Civil Systems
 ESW GmbH | Business Unit Sensors
 Pruessingstrasse 41 | 07745 Jena | Germany
 Phone +49 3641 65-3041 | Fax -3573
 lasersensors.dcs@jenoptik.com
 www.jenoptik.com/lasersensors