

TIPS® P603 LARGE ANGLE TILT SENSOR

High-resolution tilt feedback for industrial and scientific applications

- Non-contacting inductive technology to eliminate wear
- Angle set to customer's requirement
- Compact and self-contained
- High durability and reliability
- High accuracy and stability
- Sealing to IP67



As a leading designer and manufacturer of linear, rotary, tilt and intrinsically safe position sensors, Positek® has the expertise to supply a sensor to suit a wide variety of applications.

Our P603 TIPS® (Tilt Inductive Position Sensor) is an affordable, durable, high-accuracy tilt sensor designed for industrial and scientific feedback applications. The P603, like all Positek sensors, is supplied with the output calibrated to the angle required by the customer, between 20 and 160 degrees and with full EMC protection built in. The sensor provides a linear output characteristic with angle of deflection. There is a machined registration mark to identify the calibrated mid point.

It is particularly suitable for OEMs seeking good sensor performance for arduous applications such as industrial machinery where cost is important.

Overall performance, repeatability and stability are outstanding over a wide temperature range. Electrical connections to the sensor are made via an industrial standard 4-pin M12 connector, with limited rotational capability to facilitate cable routing.

The sensor has a rugged stainless steel body and anodised aluminium mounting flange. The flange has two 4.5mm by 30 degree wide slots on a 48mm pitch to simplify mounting and position adjustment. The P603 offers a range of electrical options. Environmental sealing is to IP67.

SPECIFICATION

DIMENSIONS

Body diameter	35 mm
Body Length (to seal face)	44 mm standard, 50 mm buffered

For full mechanical details see drawing P603-11

Independent linearity/Hysteresis

(combined error)	< ± 0.25 degrees
Temperature coefficients	< ± 0.01%/°C Gain & < ± 0.01%FS/°C Offset

Typical overall accuracy

< ± 0.5%/ FSO

Response time

250 mS @ 20°C typ.

Resolution

Infinite

Damping ratio

0.2 : 1 (0.6 nom. @ 25°C)

Noise

< 0.02% FSO

Environmental Temperature Limits

Operating	-40 to +125°C standard -20 to +85°C buffered
Storage	-40 to +125°C

Sealing

IP67

EMC Performance

EN 61000-6-2, EN 61000-6-3

Vibration

IEC 68-2-6: 10g

Shock

IEC 68-2-29: 40 g

MTBF

350,000 hrs 40°C Gf

Drawing List

P603-11 Sensor Outline

Drawings, in AutoCAD® dwg or dxf format, available on request.

Do you need a position sensor made to order to suit a particular installation requirement or specification? We'll be happy to modify any of our designs to suit your needs - please contact us with your requirements.

TIPS[®] P603 LARGE ANGLE TILT SENSOR

High-resolution tilt feedback for industrial and scientific applications

How Positek's PIPS[®] technology eliminates wear for longer life

Positek's PIPS[®] technology (Positek Inductive Position Sensor) is a major advance in displacement sensor design. PIPS[®]-based displacement transducers have the simplicity of a potentiometer with the life of an LVDT/RVDT.

PIPS[®] technology combines the best in fundamental inductive principles with advanced micro-electronic integrated circuit technology. A PIPS[®] sensor, based on simple inductive coils using Positek's ASIC control technology, directly measures absolute position giving a DC analogue output signal. Because there is no contact between moving electrical components, reliability is high and wear is eliminated for an exceptionally long life.

PIPS[®] overcomes the drawbacks of LVDT technology – bulky coils, poor length-to-stroke ratio and the need for special magnetic materials. It requires no separate signal conditioning.

Our LIPS[®] range are linear sensors, while RIPS[®] are rotary units and TIPS[®] are for detecting tilt position. Ask us for a full technical explanation of PIPS[®] technology.

We also offer a range of ATEX-qualified intrinsically-safe sensors.

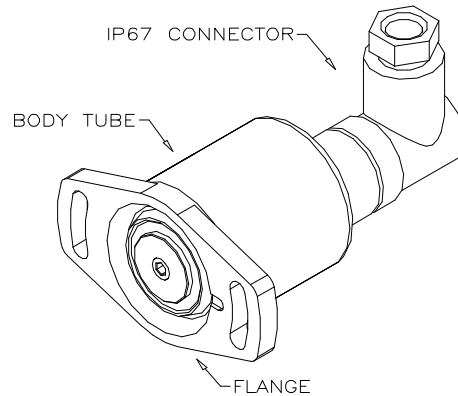

TABLE OF OPTIONS

MEASUREMENT RANGE: Factory-set to any angle from $\pm 10^\circ$ to $\pm 80^\circ$ in increments of 1 degree.

ELECTRICAL INTERFACE OPTIONS

OUTPUT SIGNAL	SUPPLY INPUT	OUTPUT LOAD
Standard: 0.5-4.5V dc ratiometric	+5V dc nom. $\pm 0.5V$.	2k Ω min.
Buffered:		
0.5-4.5V dc	+24V dc nom. + 9-28V.	2k Ω min.
$\pm 5V$ dc	$\pm 15V$ dc nom. $\pm 9-28V$.	2k Ω min.
0.5-9.5V dc	+24V dc nom. + 13-28V.	5k Ω min.
$\pm 10V$ dc	$\pm 15V$ dc nom. $\pm 13.5-28V$.	5k Ω min.
Supply Current	10mA typical, 20mA maximum.	
4-20mA (2 wire)	+24 V dc nom. + 18-28V.	300 Ω @ 24V.
(3 wire sink)	+24 V dc nom. + 13-28V.	950 Ω @ 24V.
(3 wire source)	+24 V dc nom. + 13-28V.	300 Ω max.

Output Characteristic - Standard

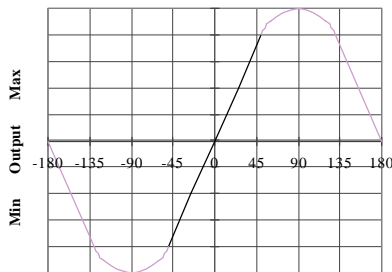

Angular Rotation

Output Characteristic - Reverse option

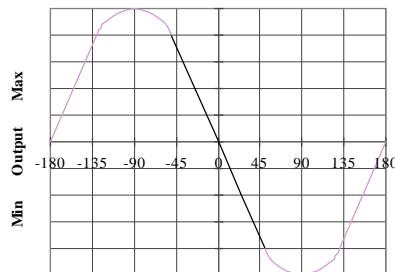

Angular Rotation