

# Ultrasonic Fuel Flow Meter

Commercial Unit 2015



## FLOW MEASUREMENT

<b>Accuracy</b>	± 0.5% accuracy at flow rates >700ml/min
<b>Measurement Range</b>	+/- 8000ml/min
<b>Flow Measurement Rate</b>	1 kHz internal measurement rate CAN outputs at 100Hz, With filtering (1)
<b>Flow Pressure Loss</b>	ISOPAR C: 5kPa@2000ml/min, 16kPa@4000ml/min. LM24 Diesel: 75kPa@8000ml/min. All at 25°C



## TEMPERATURE MEASUREMENT

<b>Measurement Type</b>	2 x PT-1000 immersed sensors at fuel inlet and outlet
-------------------------	---

## ELECTRICAL

<b>Supply Voltage</b>	4.75VDC – 22.0VDC
<b>Supply Current</b>	<100 mA @12-17VDC <180mA @4.75-5.5VDC
<b>Supply Voltage Protection</b>	Reverse polarity -38V Over voltage 58V No surge clamping

## CONNECTION

Pin	Function	Connector Pin Numbers
1	Supply (+)	<p>ASDD006-09-PD-FI-952K</p>
2	CAN High 1 (CANH1)	
3	CAN Low 1 (CANL1)	
4	Do not connect	
5	Do not connect	
6	RS-485 (A)	
7	RS-485 (B)	
8	CAN ID select resistor	
9	Ground (-)	

## CONFIGURATION INTERFACE

<b>Interface Type</b>	RS-485 Half-Duplex (2-Wire) with networking. Encrypted. No termination.
-----------------------	---

## ENVIRONMENTAL

<b>Storage Temperature</b>	-40°C to +85°C
<b>Operating Temperature</b>	-20°C to +85°C (2)
<b>Environmental Protection</b>	IP68, 300kPa for 2 hours in water (excluding electrical connector) (3) (4)
<b>EMC</b>	Not rated
<b>External Pressure Rating</b>	300kPa (excluding connector) (3)
<b>Intrinsic Safety Rating</b>	None. Not IS rated by design.

## CAN COMMUNICATIONS

<b>Design Standard</b>	ISO 11898-2 (High Speed Applications)
<b>Message Format</b>	2.0A (11 bit identifier)
<b>Baud Rate</b>	1Mbit/sec
<b>Base Message ID</b>	0x190 to 0x193
<b>'Multiple Fit' Message IDs (5)</b>	0x190 to 0x193 22k 0x194 to 0x197 5k6 0x198 to 0x19B 1k8 (6)
<b>CAN Termination</b>	None

## MECHANICAL

<b>Mass</b>	235g dry
<b>Fuel Volume</b>	11ml
<b>Wetted Materials (7)</b>	Aluminium alloy anodised to ISO 7599 PTFE, PEEK *
<b>Meter Connector</b>	Deutsch ASDDD006-09-PD-FI-952K
<b>Mating Connector</b>	Deutsch ASDDD606-09-SD-FI-952K
<b>Fuel Compatibility</b>	Petroleum, Diesel, Bio Fuels, Race Fuels ( LM24 Petroleum, LM24 Diesel, F1 Petroleum Blends)
<b>Fuel Pressure</b>	50kPa to 2000kPa operating, 6000kPa survival (8)

- (1) Output availability is subject to calibration procedure.
- (2) Limited by some electronic part ratings. All internal materials in contact with fuel are rated at 110°C.
- (3) See manufacture's specification for electrical connector rating.
- (4) Design Standard.
- (5) "Multiple Fit" is a configurable feature which allows meters to be dynamically allocated a CAN base ID through the use of different resistor values across Pin 8 and 9.
- (6) Resistor: maximum 3V applied, typically fitted within the mating connector.
- (7) Internal materials in flow path excluding fuel connector/union.
- (8) Cavitation and entrained gas can cause meter damage and spurious measurement results, this must be avoided by appropriate system design and flow meter operation.

Specifications are subject to change without notice.  
\* Colours may vary.

Part Number: 4142-00-033

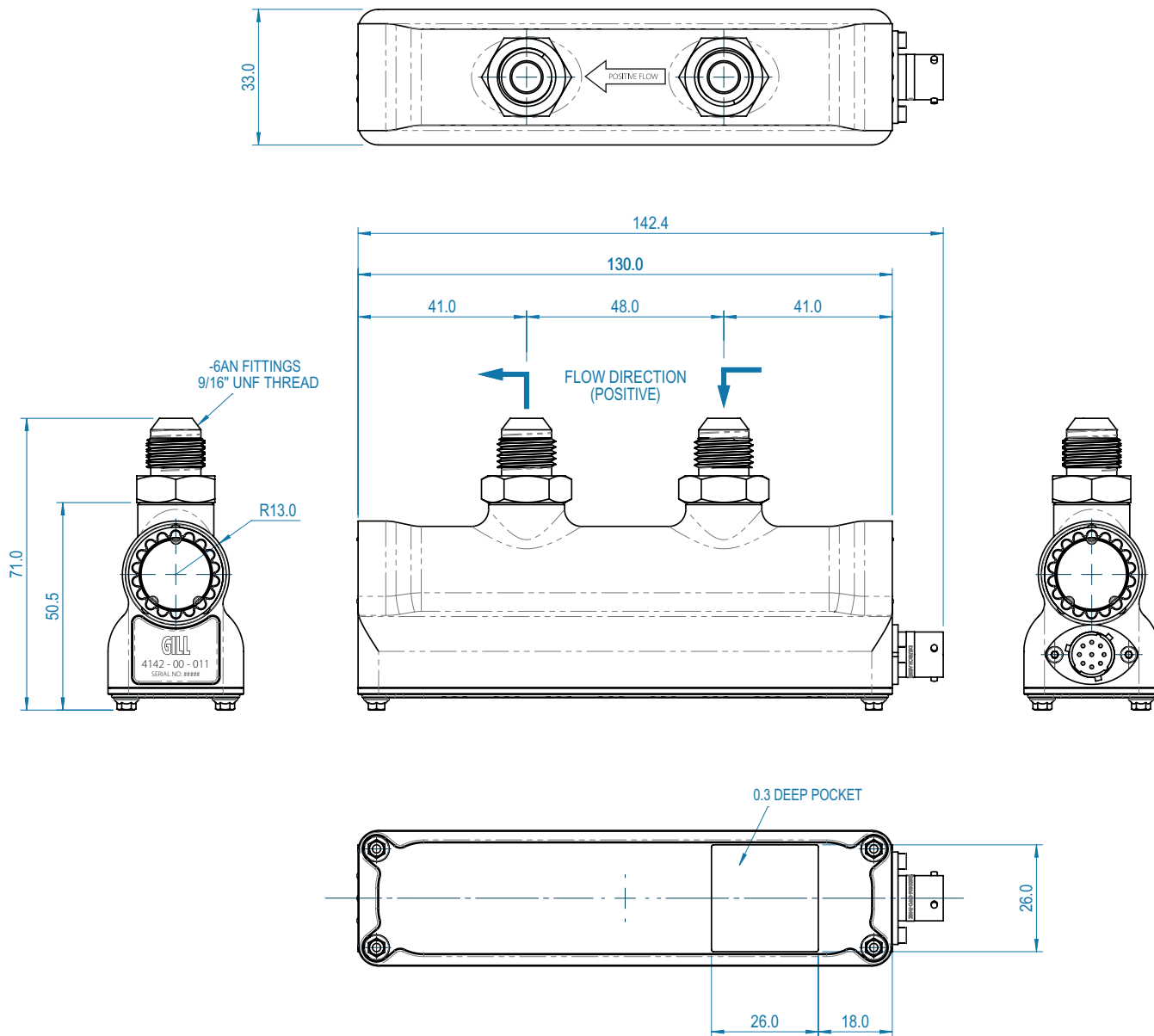

## Gill Sensors & Controls Limited

Unit 600 Ampress Park  
Lymington, Hampshire  
SO41 8LW, UK

Tel: +44 (0) 1590 613 900  
Fax: +44 (0) 1590 613 901  
info@gillsc.com



[www.gillsc.com](http://www.gillsc.com)

Issue 5

Copyright © Gill Motorsport Systems Limited 2015

Gill Motorsport Systems Limited, Reg No. 8800432  
Registered Office: The George Business Centre, Christchurch Road, New Milton, BH25 6QJ