







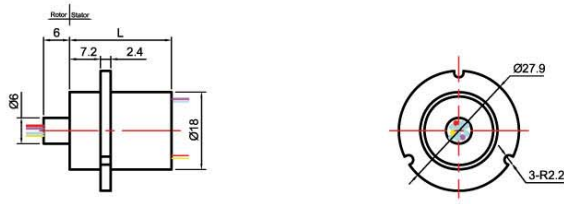

SRC018系列 (SRC018 series)

型号 Type	外形尺寸 (Outline dimension) 单位 (Unit) mm
 标准型 (Standard) SRC018	
 A1型 ("A1" Model) SRC018A1	
 A2型 ("A2" Model) SRC018A2	
 B型 ("B" Model) SRC018B	
 C型 ("C" Model) SRC018C	

电气技术指标 Electrical data

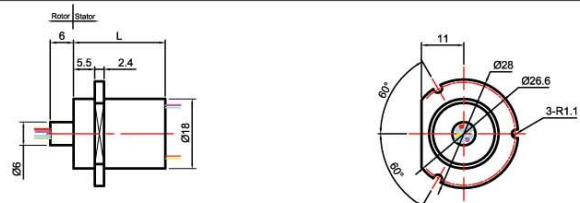
机械技术指标 Mechanical data

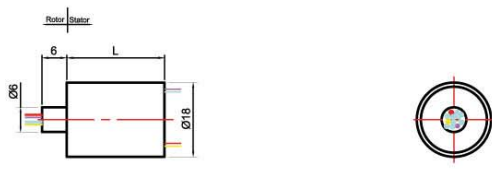
规格表 Specification List

参数	Specification	单位	Unit
电压	Voltage	240VDC—240VAC	
电流	Current	标准每环为2A	2A/ring
导线大小	Lead size	AWG28彩色铁氟龙绝缘导线 Colour coded FPE insulated lead wires	
导线长度	Standard Lead length	250mm或根据客户要求提供 250mm(other length on request)	
绝缘体强度	High pot	500VAC@50Hz, 60s	
绝缘电阻	Insulation Resistance	1000MΩ/500VDC	
动态接触电阻变化值	Dynamic contact Resistance	<0.01Ω	

参数	单位
Specification	Unit
工作速度	Operate Speed
温度范围	Temperature range
接触材料表面	Contact material surface
轴承	The steel bearing

型号	环数	长度
Type	#Rings	"L"
SRC018-6	6	15.9
SRC018-12	12	23.7
SRC018-14	14	25.5
SRC018-18	18	31.5

可按客户要求订制各种滑环, 也可提供OEM产品
Manufacture the slip ring according to customer's request, We also welcome OEM to join us.