

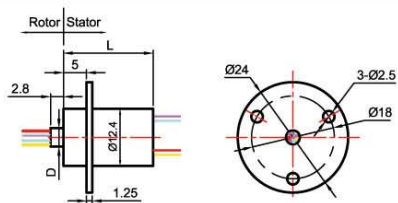









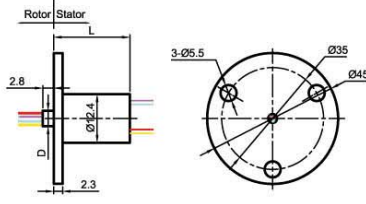

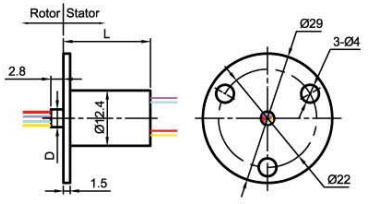
# SRC012系列 (SRC012 series)

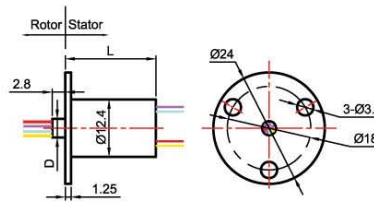
型号 Type	外形尺寸 (Outline dimension) 单位 (Unit) mm
 标准型 (Standard) SRC012	
 A型 ("A" Model) SRC012A	
 A1型 ("A1" Model) SRC012A1	
 A2型 ("A2" Model) SRC012A2	
 B型 ("B" Model) SRC012B	
 C型 ("C" Model) SRC012C	
 F型 ("F" Model) SRC012F	

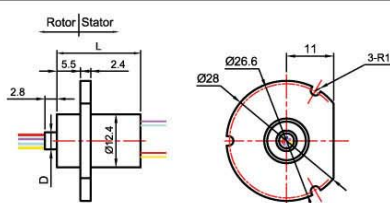
可按客户要求订制各种滑环,也可提供OEM产品

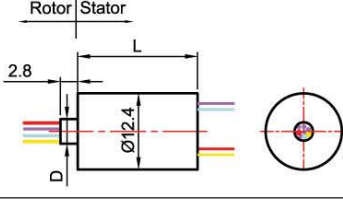
Manufacture the slip ring according to customer's request, We also welcome OEM to join us.

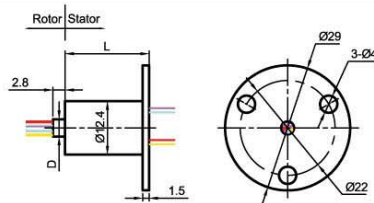
## 电气技术指标 Electrical data

参数 Specification	单位 Unit
电压 Voltage	240VDC—240VAC
电流 Current	标准每环为2A 2A/ring
导线大小 Lead size	AWG28彩色铁氟龙绝缘导线 Colour coded FPE insulated lead wires
导线长度 Standard Lead length	250mm或根据客户要求提供 250mm(other length on request)
绝缘体强度 High pot	500VAC@50Hz, 60s
绝缘电阻 Insulation Resistance	1000MΩ/500VDC
动态接触电阻变化值 Dynamic contact Resistance	< 0.01 Ω

滑环寿命由工作转速, 工作环境工作温度决定

The life-span of the slip ring is decided by the rotating speed, working environment and the surrounding temperature.

## 规格表 Specification List

型号 Type	环数 #Rings	长度 "L"	中轴外径 "D"
SRC012-6	6	14	Φ4
SRC012-12	12	19.5	Φ4
SRC012-18	18	23	Φ5

## 机械技术指标 Mechanical data

参数 Specification	单位 Unit
工作速度 Operate Speed	250rpm
温度范围 Temperature range	-20℃—+80℃
接触材料表面 Contact material surface	金—金 Gold—gold
轴承 The steel bearing	精密小滚珠钢轴承 The precise small steel ball bearing