

# LIPS® P106 INTERNALLY MOUNTED CYLINDER SENSOR WITH EXTERNAL ELECTRONICS

High-resolution position feedback for hydraulic and pneumatic cylinders

- Non-contacting inductive technology to eliminate wear
- Travel set to customer's requirement
- Compact and self-contained
- High durability and reliability
- High accuracy and stability
- Sealing to IP65/IP67 as required

As a leading designer and manufacturer of linear, rotary, tilt and intrinsically safe position sensors, Positek® has the expertise to supply a sensor to suit a wide variety of applications.

Our P106 LIPS® (Linear Inductive Position Sensor) is an affordable, durable, high-accuracy position sensor designed for demanding hydraulic or pneumatic cylinder position feedback applications where service life, environmental resistance and cost are important. It is particularly suitable for OEMs seeking good sensor performance where the internal length or diameter is limited.

Overall performance, repeatability and stability are outstanding over a wide temperature range. The unit is highly compact and space-efficient, being responsive along almost its entire length. Like all Positek sensors it provides a linear output proportional to displacement, each unit is supplied with the output calibrated to the travel required by the customer, from 20 to 600mm and with full EMC protection built in.

The P106 is very rugged, being made of stainless steel with an inert fluoropolymer-sheathed probe with the option of either an aluminium or stainless steel target tube. The probe and target are easy to install, as is the electronics module which has a range of mounting and electrical options. Sealing to IP65 or IP67 depending on selected cable or connector options.



## SPECIFICATION

### DIMENSIONS

Probe Diameter	Dia: 20mm,
Probe Length:	measurement length + 62 mm
Electronics Module Diameter	35 mm
Electronics Module Length	from 40 - 47 mm, see drawing P106-12
Target Tube Length	measurement length + 30mm, ID 7.7mm, OD 9.45mm

*For full mechanical details see drawings P106-11 and P106-12*

**Independent linearity**  
 < ± 0.25% up to 450mm @ 20°C  
 < ± 0.5% over 450mm @ 20°C

**Temperature coefficients**  
 < ± 0.01%/°C Gain &  
 < ± 0.01%FS/°C Offset

**Typical overall accuracy**

**Frequency response**  
 < ± 0.75% FSO  
 > 10 KHz (-3dB)  
 > 300 Hz (-3dB) 2 wire 4 to 20 mA

**Resolution**

**Noise**  
 Infinite  
 < 0.02% FSO

**Environmental Temperature Limits**

**Operating**  
 -40 to +125°C standard

-20 to +85°C buffered

**Storage**  
 -40 to +125°C

**Sealing**  
 IP65/IP67 depending on connector / cable option

**Hydraulic Pressure**  
 350Bar

**EMC Performance**  
 EN 61000-6-2, EN 61000-6-3

**Vibration**  
 IEC 68-2-6: 10g

**Shock**  
 IEC 68-2-29: 40 g

**MTBF**  
 350,000 hrs 40°C Gf

**Drawing List**

P106-11	Probe Outline
P106-12	Electronics Module Outline
P106-13	Typical Target Installation details
TG24-11	Optional Target Tube Flange details

**Do you need a position sensor made to order to suit a particular installation requirement or specification? We'll be happy to modify any of our designs to suit your needs - please contact us with your requirements.**

# LIPS<sup>®</sup> P106 INTERNALLY MOUNTED CYLINDER SENSOR WITH EXTERNAL ELECTRONICS

High-resolution position feedback for hydraulic and pneumatic cylinders

## How Positek's PIPS<sup>®</sup> technology eliminates wear for longer life

Positek's PIPS<sup>®</sup> technology (Positek Inductive Position Sensor) is a major advance in displacement sensor design. PIPS<sup>®</sup>-based displacement transducers have the simplicity of a potentiometer with the life of an LVDT/RVDT.

PIPS<sup>®</sup> technology combines the best in fundamental inductive principles with advanced micro-electronic integrated circuit technology. A PIPS<sup>®</sup> sensor, based on simple inductive coils using Positek's ASIC control technology, directly measures absolute position giving a DC analogue output signal. Because there is no contact between moving electrical components, reliability is high and wear is eliminated for an exceptionally long life.

PIPS<sup>®</sup> overcomes the drawbacks of LVDT technology – bulky coils, poor length-to-stroke ratio and the need for special magnetic materials. It requires no separate signal conditioning.

Our LIPS<sup>®</sup> range are linear sensors, while RIPS<sup>®</sup> are rotary units and TIPS<sup>®</sup> are for detecting tilt position. Ask us for a full technical explanation of PIPS<sup>®</sup> technology.

We also offer a range of ATEX-qualified intrinsically-safe sensors.

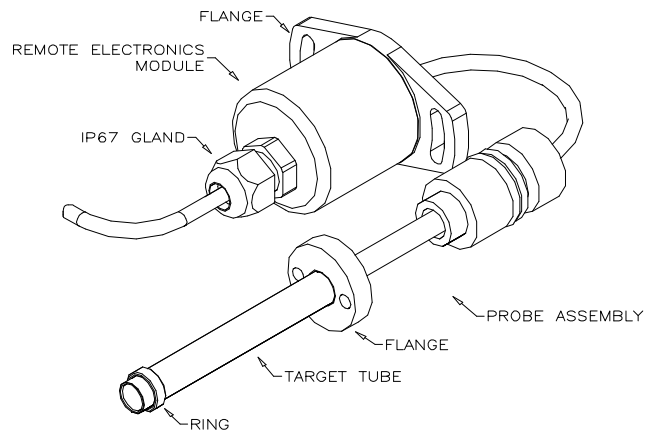

### TABLE OF OPTIONS

**MEASUREMENT RANGE:** Factory-set to any length from 20 to 600 mm in increments of 1mm.

#### ELECTRICAL INTERFACE OPTIONS

OUTPUT SIGNAL	SUPPLY INPUT	OUTPUT LOAD
Standard: 0.5-4.5V dc ratiometric	+5V dc nom. ± 0.5V.	2kΩ min.
Buffered: 0.5-4.5V dc	+24V dc nom. + 9-28V.	2kΩ min.
±5V dc	±15V dc nom. ± 9-28V.	2kΩ min.
0.5-9.5V dc	+24V dc nom. + 13-28V.	5kΩ min.
±10V dc	±15 V dc nom. ± 13.5-28V.	5kΩ min.
Supply Current	10mA typical, 20mA maximum.	
4-20mA (2 wire)	+24 V dc nom. + 18-28V.	300Ω @ 24V.
(3 wire sink)	+24 V dc nom. + 13-28V.	950Ω @ 24V.
(3 wire source)	+24 V dc nom. + 13-28V.	300Ω max.

Option for output signal 'zero' and 'span' adjustment available.

#### CONNECTOR/CABLE OPTIONS

Connector - Hirschmann GD series IP65  
 Cable with M12 gland or short gland IP67  
 Cable length >50cm – please specify length in cm

#### ELECTRONICS MODULE MOUNTING OPTIONS

Flange 2 off 4.5 mm x 30 degree wide slots, 48 mm PCD.  
 M18 male thread 30mm hex AF, Ø30mm seal face.  
 Supplied with O-ring seal.

#### FLANGE OPTIONS

Penny & Giles HLP100, Temposonics (M4 fixing) and Parker Hannifin cylinders versions available.

Output Characteristic - Standard

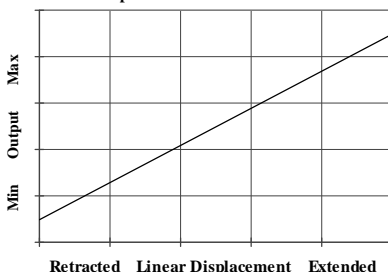

Output Characteristic - Reverse option

