

mtc MTM-54-13B

DC Torque Motor

The MTM-54-13B is a direct-drive DC torque motor. The MTM-54-13B is a permanent rare earth magnet, with continuous rotation and armature excited. The MTM-54-13B have usage where very high torque to power, volume and weight ratios are needed. These applications include missile and aircraft actuators, diagnostic medical instrumentation, ground and airborne radar antennas.

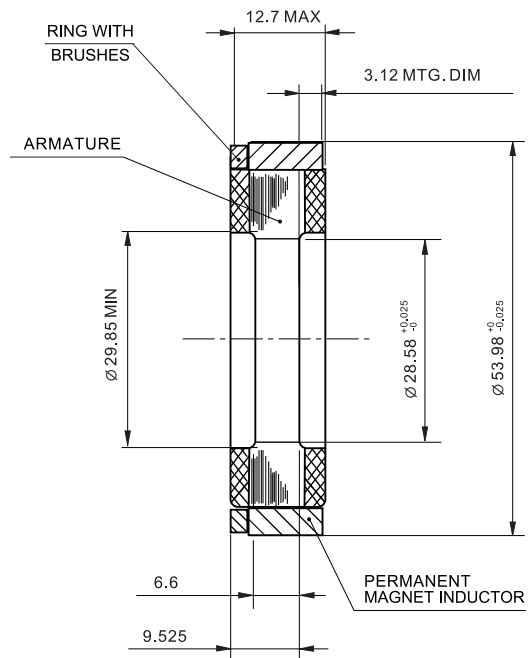
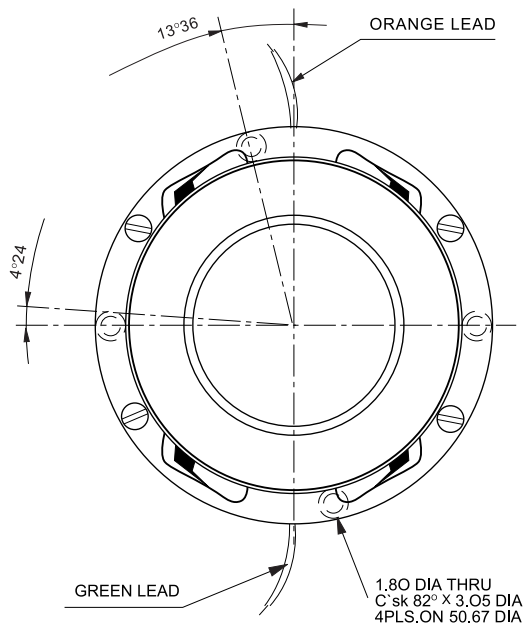
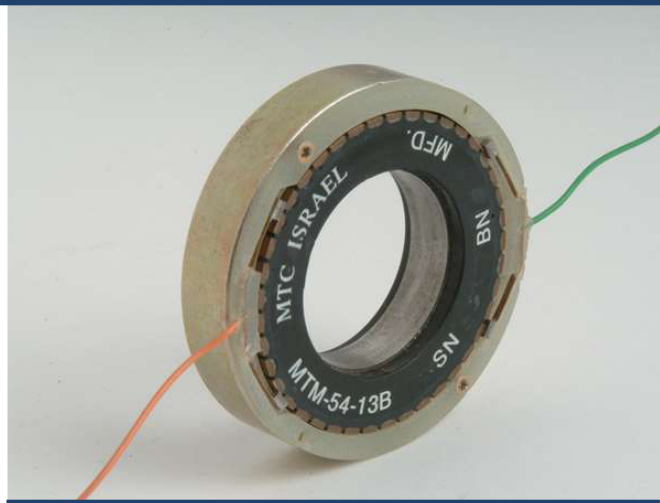

Specification

Parameter	Unit	Value
Peak Torque (T_P)	N*m	0.318
No load speed (ω_{NL})	rad/sec	260
Total breakaway torque (T_F)	N*m	$12 * 10^{-3}$
Ripple torque (T_R)	%(avg.to pk.)	6
Temperature rise	°C/Watts	7
Max. allowable winding temperature	°C	150
Moment of inertia (J_M)	gr*cm ²	220
Weight	gr	108
Damping factor at 25°C (F_D)	N*m/rad/sec	$1.2 * 10^{-3}$
Elect. time constant at 25°C (T_E)	sec	$2 * 10^{-4}$

Winding Constant

Parameter	Unit	Value	Tolerance
Resistance at 25°C (R_M)	Ohm	9.9	± 12.5%
Torque sensitivity (K_T)	N*m/Amp	0.107	± 10%
Back EMF constant (K_B)	Volt/rad/sec	0.12	± 10%
Inductance (L_M)	mHy	1.8	± 30%