



SPECIFICATIONS

Item No.: ACA826T

Description: High Accuracy Digital Type Dual-Axis Inclinometer
with Full Temperature Compensation

Production implementation standard reference

- Enterprise quality system standards: ISO9001: 2008 standard (certification number: 128101)
- Tilt sensor production standards: GB / T 191 SJ 20873-2003 inclinometer general specification of Level
- The Academy of metrology and quality inspection Calibrated in accordance to: JJF1119-2004 Electronic Level calibration Specification
- Software development reference standard: GJB 2786A-2009 military software development General requirements
- Product environmental testing standards: GJB150
- Electromagnetic anti-interference test standards: GB / T 17626
- Version: Ver.09
- Date: 2014.4.16

ACA826T-High Accuracy Digital Type Dual-Axis Inclinometer with Full Temperature Compensation



全温补 C Temperature Compensation
ACA 高精度倾角系列

General Description

ACA826T is a full temperature compensation & high accuracy dual-axis inclinometer which professionally developed by Rion Company to the field of high precision level measurement and leveling field , the maximum measuring range is $\pm 3^\circ$, high resolution 0.0005° , can completely replace the traditional high-precision level meter. Digital signal transmission, matched with professional computer software, data measure and record correctly ,output interface RS485, RS232, TTL, PWM or CAN 2.0B optional. Non-contact installation features make ACA826T with superior system integration, convenient installation only need fix the sensor on the measured surface by screws , then can automatically calculate the object horizontal inclined angle, easy to use .With strong ability resistance to external electromagnetic interference and to withstand shock and vibration, in the domestic counterparts products with absolute competitive advantage.

Features

- Dual-Axis Inclinometer
- Size: L92×W48×H36mm
- Wide temperature working: $-40\sim+85^\circ\text{C}$
- Resolution: 0.0005°
- Highly anti-vibration performance $>2000\text{g}$
- Output mode RS232、RS485、RS422、TTL、CAN 2.0 are optional
- Measuring Range : $\pm 1\sim\pm 3^\circ$ optional
- Wide voltage input: $9\sim 36\text{V}$
- IP67 protection class
- Water-proof air-plug

Application:

- Engineering vehicles automatic leveling
- Laser equipment position
- Underground drill posture navigation
- Precise machine tool level control
- Directional satellite communications antenna pitching angle measurement
- Bridge & dam detection
- Medical facilities angle control
- Railway gauging rule , gauge equipment leveling
- Geological equipment inclined monitoring



ACA826T-High Accuracy Digital Type Dual-Axis Inclinometer with Full Temperature Compensation

Ordering information:

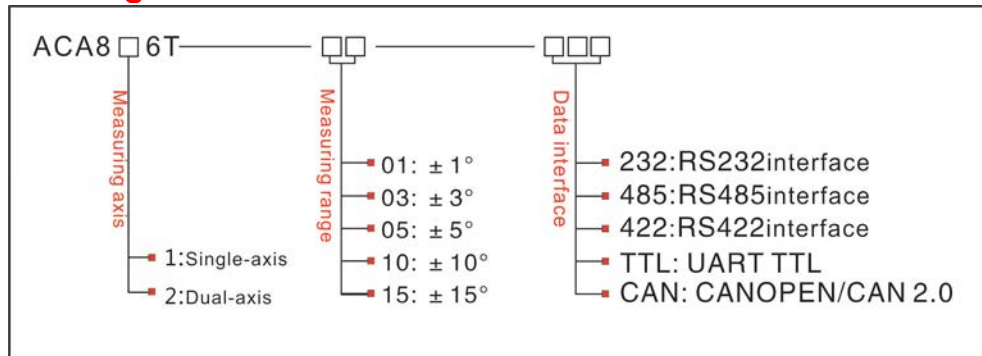

E.g: ACA826T-01-232: Dual-axis/Standard/ $\pm 01^\circ$ Measuring range/RS232 output

Technical Data

Parameters	Conditions	ACA826T-03	ACA826T-10	ACA826T-15	unit
unit					
Measuring range		± 03	± 10	± 15	$^\circ$
Measuring axis		X Y	XY	X Y	
Resolution		0.0005	0.0005	0.0005	$^\circ$
Absolute accuracy		0.001	0.005	0.006	$^\circ$
Long term stability		0.002	0.003	0.005	
Zero temperature coefficient	$-40\sim 85^\circ$	± 0.0008	± 0.0008	± 0.0008	$^\circ/\text{C}$
Sensitivity temperature coefficient	$-40\sim 85^\circ$	≤ 50	≤ 50	≤ 50	ppm/ $^\circ\text{C}$
Power on time		0.5	0.5	0.5	S
Response time		0.05	0.05	0.05	S
Output rate	5Hz、15Hz、35Hz、50Hz can be setting				
Output signal	RS232/RS485/RS422/TTL/CAN				
Electromagnetic compatibility	According to EN61000 and GBT17626				
MTBF	≥ 50000 hours/times				
Insulation Resistance	$\geq 100\text{M}$				
Shockproof	100g@11ms、Times/Axis(half sinusoid)				
Anti-vibration	10grms、10~1000Hz				
Protection glass	IP67				
Cables	Standard 1M length、wearproof、wide temperature、Shielded cables4*0.4mm2 air-plug connector				
Weight	150g(without cable)				

ACA826T-High Accuracy Digital Type Dual-Axis Inclinometer with Full Temperature Compensation

Electronic Characteristics

Parameters	Conditions	Min	Standard	Max	Unit
Power supply	Standard	9	12、24	36	V
	customized		Other voltage		V
Working current	No-load		50		mA
Working temperature		-40		+85	°C
Store temperature		-55		+100	°C

Key words :

Resolution: Refers to the sensor in measuring range to detect and identify the smallest changed value.

Absolute accuracy: Refers to in the normal temperature circumstances, the sensor absolute linearity, repeatability, hysteresis, zero deviation, and transverse error comprehensive error.

Long term stability : Refers to the sensors in normal temperature conditions, the deviation between the maximum and minimum values after a year's long time work.

Response time: Refers to the sensor in an angle change, the sensor output value reached the standard time required.

Mechanical Parameters

- Connectors: 1m cable with air-plug connector (customized)
- Protection glass: IP67(air plug connector)
- Enclosure material : Aluminum Oxide
- Installation : 4*M4 screws
2*3mm plug position(optional)



Working Principle

Adopt the European import of core control unit, using the capacitive micro pendulum principle and the earth gravity principle, when the the inclination unit is tilted, the Earth's gravity on the corresponding pendulum will produce a component of gravity, corresponding to the electric capacity will change, by enlarge the amount of electric capacity , filtering and after conversion then get the inclination.

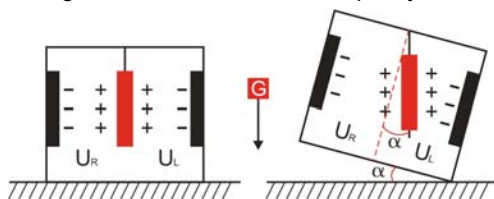

U_R, U_L Respectively is the pendulum left plate and the right plate corresponding to their respective voltage between the electrodes, when the tilt sensor is tilted, U_R, U_L Will change according to certain rules, so $f(U_R, U_L,)$ On the inclination of α function:

$$\alpha = f(U_R, U_L,)$$

ACA826T-High Accuracy Digital Type Dual-Axis Inclinometer with Full Temperature Compensation

Measuring Directions&Fix

The installation must guarantee the product bottom is parallel to measured face, and reduce the influence of dynamic and acceleration to the sensor. This product can be installed horizontally or mounted vertically (mounted vertically selection is only applicable to the single axis), for installation please refer to the following scheme.

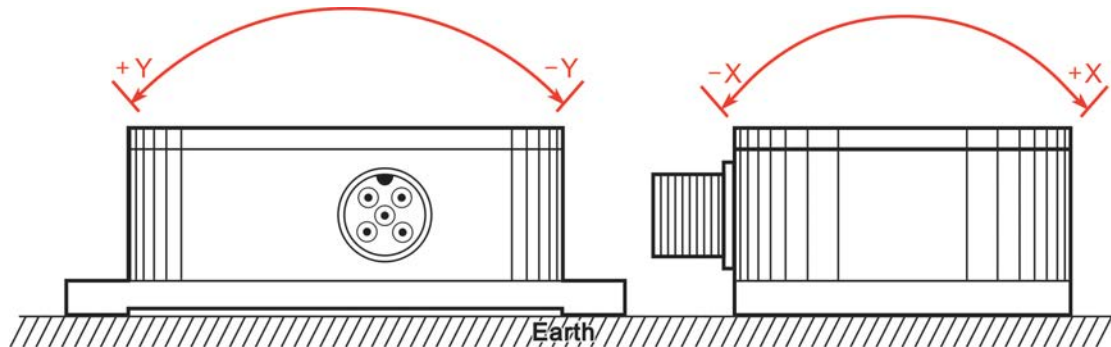

Production installation notes :

Please follow the correct way to install tilt sensor, incorrect installation can cause measurement errors, with particular attention to the "surface", "line": 1) The Sensor mounting surface and the measured surface must be fixed closely, smoothly, stability,if mounting surface uneven likely to cause the sensor to measure the angle error. See Figure Pic.AB

2) The sensor axis and the measured axis must be parallel ,the two axes do not produce the angle as much as possible. See Figure Pic.CD

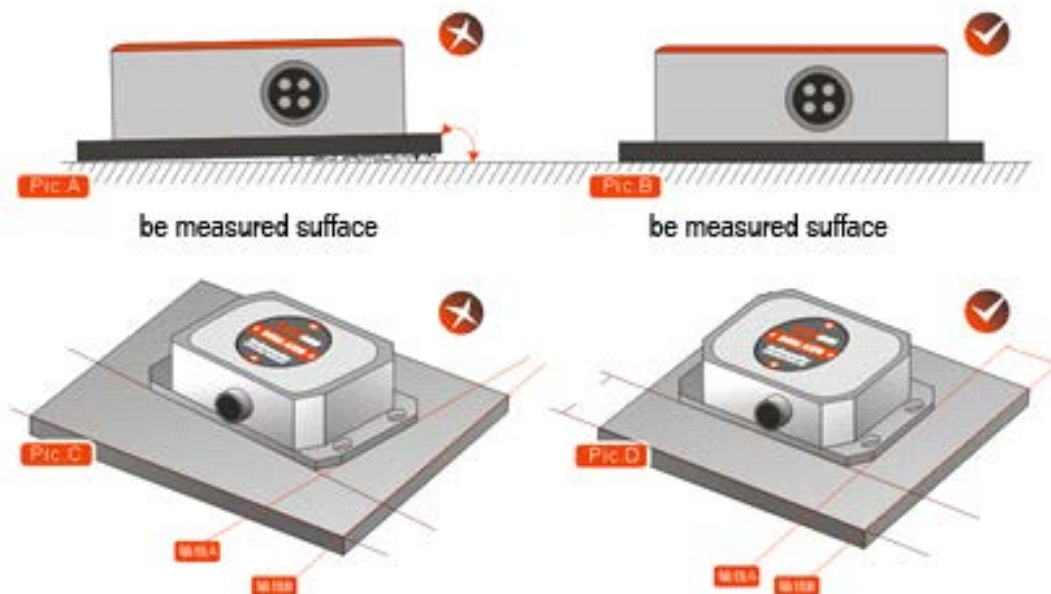

ACA826T-High Accuracy Digital Type Dual-Axis Inclinometer with Full Temperature Compensation

Dimension

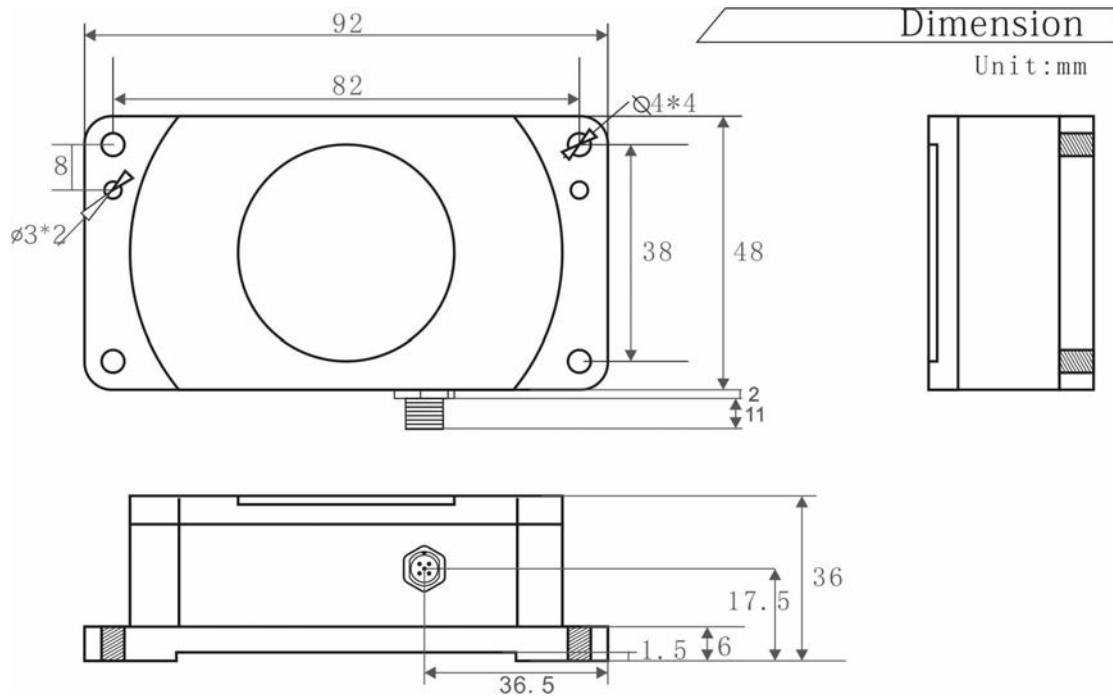

Size: L92×W48×H36mm

Electrical Connection

Line color function	BLACK	WHITE	BLUE	BROWN	GRAY
	GND Power Negative	RS232(RXD) Or RS485(D+)	RS232(TXD) Or RS485(D-)	Vcc 9~36V Power supply positive	FACTORY Use only

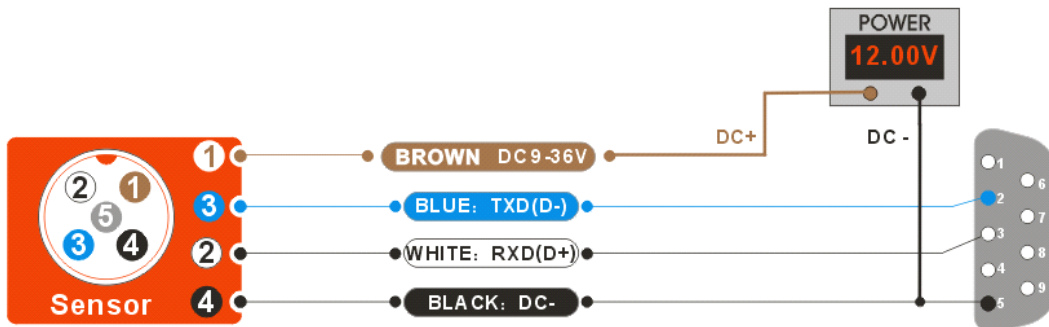

ACA826T-High Accuracy Digital Type Dual-Axis Inclinometer with Full Temperature Compensation

RION serial port tester software

You can download the RION angle debugging software from RION's official website for the preliminary angle debugging, also you Can download public version of the serial port assistant software on line for using .

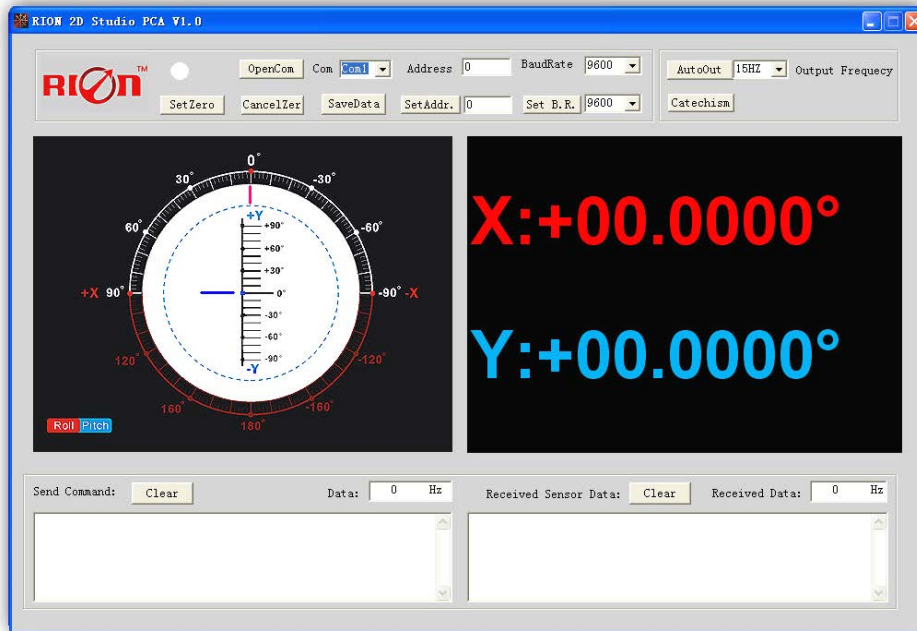

Open/Close: Open and close COM port;

Com: Select the the device corresponding to the COM port

Address: Fill in the sensor current address code, the factory default is 00

Set Address: Set the sensor address code input box on the right to enter the desired address code, click Set Addr button

Save Data: Save the data, click here data can be synchronized Save angle data, the file is stored by default in the C: ---- COMDATA file

Set Zero: Set relative zero, the sensor current angle is 00.00 degrees

Cancel Zero: Unset the relative zero, to restore the sensor to the factory absolute zero;

Baud Rate: Select the sense baud rate , the factory default is 9600;

Set Baud Rate: Set the sensor baud rate, on the right of the selection box to select corresponding baud rate then click SetB.R. button;

Auto Output: Switch the sensor to automatically output mode, in the automatic output mode can be filled with different output frequency in Hz;

Catechism: The sensor switch to answer pattern, such as choosing the answer type, must input "send command "(command, please refer to the specification) on the left of "Send Command" input box, but also can fill in the transmit frequency in the Send Data, the unit Hz;

Note: after install the RION's debugging software, if can not open, please operate by the following steps (please appear to the administrator status to operate):

- 1) Copy these three files mscomm.srg、mscomm32.ocx、mscomm32.dep from the folder to C:/Windows/system32 path below。
- 2) Click "Start" --"run" --regsrv32 mscomm32.ocx, You are prompted to install successful dialog。

ACA826T-High Accuracy Digital Type Dual-Axis Inclinometer with Full Temperature Compensation

Product Protocol

1. DATA FRAME FORMAT:

(8 bits data, 1 bit stop, No check, Default baud rate 9600)

Identifier (1byte)	Date Length (1byte)	Address code (1byte)	Command word (1byte)	Date domain	Check sum (1byte)
68					

Date format: hexadecimal

Identifier: Fixed68

Data length: From data length to check sum (including check sum) length

Address code: Accumulating module address, Default :00

Date domain will be changed according to the content and length of command word

Check sum: Data length、Address code、Command word and data domain sum, No carry.

二、COMMAND word analysis

Desc.	Meaning/Example	Description
0X04	Meanwhile read angle command E.g: 68 04 00 04 08	Data domain(0byte) No Data domain command
0X84	sensor data response Eg: 68 10 00 84 00 00 20 08 10 00 25 28 10 35 00 80 DE	data field(9byte) 68 is prefix of data packets, fixed. 10 is data length, fixed. 00 is address code, revisable. 84 is command code, fixed. 00 00 20 08 the four red bytes are the X axis returned angle value in compact BCD code. the high order 0 of first byte is sign bit(0: positive; 1: negative), 00 0 are three digit integer value, 20 08 are four decimal digit. other axis data analysis method is similar. the angle is +000.2008 deg by analyzing. 10 00 25 28 , the four blue bytes are Y axis returned angle value, analysis method is similar to X axis 10 35 00 80 , the four green bytes are internal temperature value, analysis method is similar to X axis. DE check sum, hexadecimal sum of all data, exclude prefix 68, if surpass one byte, pick low-order.
0X05	Setting relative/absolute ZERO: Can set the current angle to Zero degree, relative measurement, can also be set to absolute ex-factory zero, power off save E.g: 68 05 00 05 00 0A	Data domain (1byte) 00: absolute ZERO 01: relative ZERO
0X85	Sensor answer reply command	Data domain (1byte)

ACA826T-High Accuracy Digital Type Dual-Axis Inclinometer with Full Temperature Compensation

	E.g: 68 05 00 85 00 8A	Data domain in the number means the sensor response results 00 Setting successfully FF Setting failure
0X0B	Setting communication rate E.g: 68 05 00 0B 03 13 The command setting is effective after power off then restart (power off with save function)	Data domain (1byte) Baud rate: default :9600 00 means 2400 01 means 4800 02 means 9600 03 means 19200 04 means 38400 05 means 115200
0X8B	Sensor answer reply command E.G: 68 05 00 8B 90	Data domain (1byte) Data domain in the number means the sensor response results 00 Success FF Failure
0X0C	Setting sensor output mode Response rule; Need upper computer send reading angle command , the sensor answer the corresponding angle Automatic output rule: The sensor with power on can Automatically output X angle , The output frequency base on what be settled, if you need output High frequency, please set baud rate as 115200 (Power off with save function) E.g: 68 05 00 0C 00 11	Data domain (1byte) Factory default: 00 00 Answer reply mode 01 5Hz Automatical output mode 02 15Hz Automatical output mode 03 25Hz Automatical output mode 04 35Hz Automatical output mode 05 50Hz Automatical output mode
0X8C	The sensor answer reply command E.g: 68 05 00 8C 00 91	Data domain (1byte) Data domain in the number means the sensor response results 00 Success FF Failure
0X0F	Setting module address command The sensor default address is 00, 1, such as a plurality of sensor to be connected with a bus cable, e.g RS485.requires each sensor is set to a different address, in order to achieve control and response angle . 2, If successfully changed the new address, follow all of the commands and responding Packet address code has to switch to the new address code which	Data domain (1byte) XX Module address Address from 00 to EF range Note: All products have a common address :FF, If forget the address what has been set during operation , can use FF address to operate the product can still normally respond

ACA826T-High Accuracy Digital Type Dual-Axis Inclinometer with Full Temperature Compensation

	<p>already changed then to be effective, otherwise the sensor will not respond to commands.(power off with save function)</p> <p>E.g: 68 05 00 0F 01 15</p> <p>Setting the address to 01</p> <p>68 05 FF 0F 00 13</p> <p>Use the common address to reset address to 00</p>	
0X8F	<p>The sensor answer reply command</p> <p>E.g: 68 05 00 8F 94</p>	<p>Data domain (1byte) ,</p> <p>Data domain in the number means the sensor response results</p> <p>00 Success FF Failure</p>
0X0D	<p>Query relative/absolute ZERO</p> <p>Used to query the sensor current ZERO mode is relative ZERO or absolute ZERO</p> <p>E.g : 68 04 00 0D 11</p>	<p>Data domain (0byte)</p> <p>No data domain commands</p>
0X8D	<p>The sensor answer reply command</p> <p>E.g:68 05 00 8D 00 92</p>	<p>Data domain (1byte) ,</p> <p>Data domain in the number means the sensor response results</p> <p>00 Absolute ZERO</p> <p>01 Relative ZERO</p>



※More products information, please refer to the company's Website : www.rion-tech.net



深圳市瑞芬科技有限公司
CHINA SHENZHEN RION TECHNOLOGY CO.,LTD.

✓倾角传感器 ✓倾角（调平）开关 ✓数显水平仪 ✓陀螺仪
✓三维电子罗盘 ✓加速度计 ✓航姿参考系统 ✓寻北仪

T: 0755-29657137 / 29761269 F: 0755-29123494
W: www.rion-tech.net E: sales@rion-tech.net
A: 中国·深圳市宝安区82区华丰科技园 五期3F

Accurate Solution Provider
姿态测量解决方案专家！