

Model 123

Load Cell

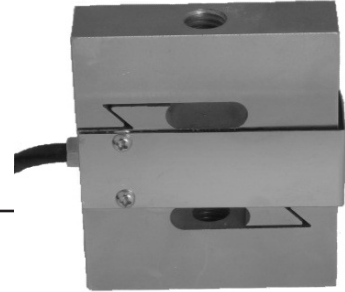

DESCRIPTION

The Model 123 load cells combines both a compact form and high precision to offer a superior tension force transducer. The one-piece S-shaped design achieves a maximum non-linearity of 0.03 % full scale for load ranges from 1000 kg to 20000 kg.

FEATURES

- 1000 kg to 20000 kg range
- ± 0.03 % accuracy
- Built-in overload resistance
- One-piece, nickel-plated alloy steel construction
- Integral cable
- Cost efficient

Model 123

PERFORMANCE SPECIFICATIONS

Characteristic	Measure
Load ranges ⁴	1000 kg to 20000 kg
Accuracy	±0.03 % full scale
Output	2.0 mV/V
Creep (max.)	±0.03 % full scale (30 minutes)

ENVIRONMENTAL SPECIFICATIONS

Characteristic	Measure
Temperature, operating	-30 °C to 70 °C [-22 °F to 158 °F]
Temperature, compensated	-20 °C to 55 °C [-4 °F to 131 °F]
Temperature effect, zero	±0.03 % full scale/10 °C
Temperature effect, span	±0.03 % full scale/10 °C
Protection class	IP67 ³

ELECTRICAL SPECIFICATIONS

Characteristic	Measure
Strain gage type	Foil
Excitation (acceptable)	10 Vdc to 12 Vdc
Excitation (max.)	15 Vdc
Insulation resistance	≥ 5000 mOhm
Bridge resistance (tolerance) - Input resistance	400 ohm ±10 ohm (nominal)
Bridge resistance (tolerance) - Output resistance	352 ohm ±2 ohm (nominal)
Zero balance (tolerance)	±1 % full scale
Electrical termination (std)	6 m [19.69 ft] of 5 mm [0.2 in] diameter cable

MECHANICAL SPECIFICATIONS

Characteristic	Measure
Maximum allowable load	120 % full scale ¹
Later load limit	100 % full scale
Material	Nickel plated alloy steel

WIRING CODES

Cable	
Red	(+) supply
Black	(-) supply
Green	(+) output
White	(-) output
Large Black	Shield

RANGE CODES

Range codes	Range
LQ	1000 kg
LR	1500 kg
LS	2000 kg
LT	3000 kg
LU	5000 kg
LV	7500 kg
LW	10000 kg
LY	15000 kg
LZ	20000 kg

MOUNTING DIMENSIONS

Range (kg)	A	B	C	D
1000, 1500	80 mm [3.15 in]	70 mm [2.76 in]	25 mm [0.98 in]	M12 x 1.75
2000, 3000, 5000	108 mm [4.25 in]	95 mm [3.75 in]	25 mm [0.98 in]	M18 x 1.5
7500, 10000	178 mm [7.00 in]	130 mm [5.12 in]	51 mm [2.0 in]	M30 x 2
15000, 20000	190 mm [7.48 in]	160 mm [6.3 in]	60 mm [2.36 in]	M30 x 2

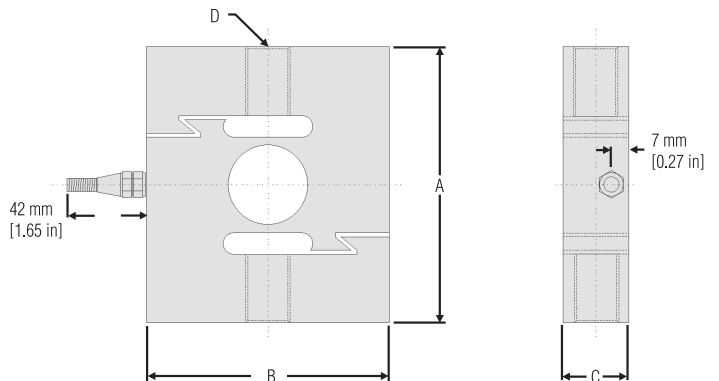

NOTES

1. Allowable maximum loads – maximum load to be applied without damage.²
2. Without damage - loading to this level will not cause excessive zero shift or performance degradation. The user must consider fatigue life for long term use and structural integrity. All structurally critical applications (overhead loading, etc.) should always be designed with safety redundant load paths.
3. IP68 rating for load ranges 7500 kg and greater.
4. This unit is calibrated to Metric (non-Imperial) units.

TYPICAL SYSTEM DIAGRAM

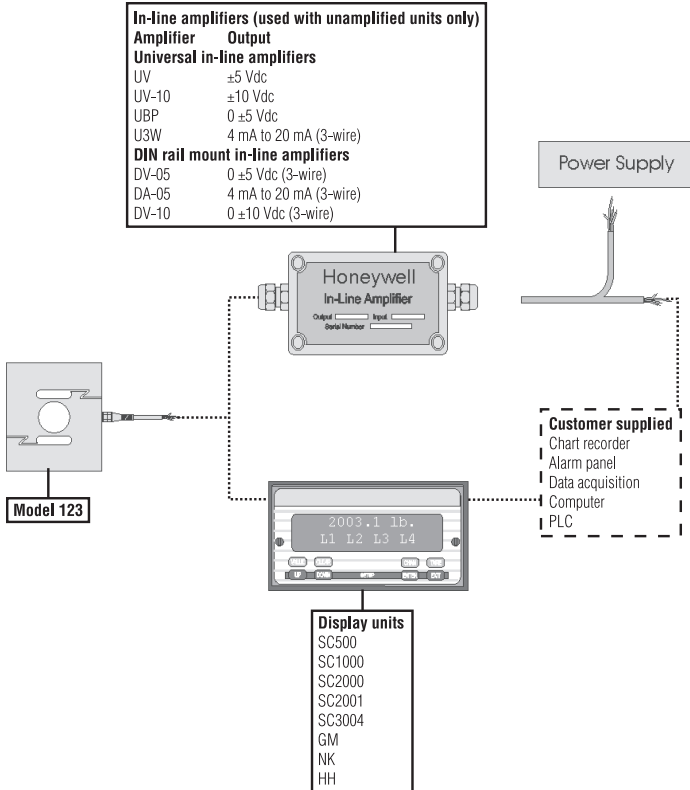

Warranty. Honeywell warrants goods of its manufacture as being free of defective materials and faulty workmanship. Honeywell's standard product warranty applies unless agreed to otherwise by Honeywell in writing; please refer to your order acknowledgement or consult your local sales office for specific warranty details. If warranted goods are returned to Honeywell during the period of coverage, Honeywell will repair or replace, at its option, without charge those items it finds defective. **The foregoing is buyer's sole remedy and is in lieu of all warranties, expressed or implied, including those of merchantability and fitness for a particular purpose. In no event shall Honeywell be liable for consequential, special, or indirect damages.**

While we provide application assistance personally, through our literature and the Honeywell web site, it is up to the customer to determine the suitability of the product in the application.

Specifications may change without notice. The information we supply is believed to be accurate and reliable as of this printing. However, we assume no responsibility for its use.

For more information about Sensing and Control products, visit www.honeywell.com/sensing or call +1-815-235-6847. Email inquiries to info.sc@honeywell.com

WARNING **PERSONAL INJURY**

- DO NOT USE these products as safety or emergency stop devices or in any other application where failure of the product could result in personal injury.

Failure to comply with these instructions could result in death or serious injury.

WARNING **MISUSE OF DOCUMENTATION**

- The information presented in this catalogue is for reference only. DO NOT USE this document as product installation information.
- Complete installation, operation and maintenance information is provided in the instructions supplied with each product.

Failure to comply with these instructions could result in death or serious injury.